

# EVOLT

## ME 1000 OWNER'S MANUAL

1000W MAX POWER  
ELECTRIC MINI BIKE



Read and understand this manual before riding!

***Always wear a helmet it could save your life! This Mini Bike is designed for operators age 12 and over. Adult supervision is required for riders age 16 and under!***

***Provincial/Municipal governments have different regulations pertaining to owning and operating an off-road vehicle, learn the regulations in your area.***

[www.evoltadventure.com](http://www.evoltadventure.com)

# Directory

Safety Warnings.....	1-2
Before You Begin.....	3
Assembly and Set-Up.....	4-7
Before Riding.....	8-9
Safety Reminders.....	10
Repair and Maintenance.....	11-17
Troubleshooting Guide.....	18-19
Side View.....	20
Electrical Diagram.....	21

***NOTE: Manual illustrations are for demonstration purposes only.  
Illustrations may not reflect exact appearance of actual product.  
Specifications subject to change without notice.***

# Safety Warnings

**⚠WARNING:** Riding an electric mini bike can be a hazardous activity. Certain conditions may cause the equipment to fail without fault of the manufacturer. Like other electric products, these vehicles can and are intended to move, and it is therefore possible to lose control, fall off and/or get into dangerous situations that no amount of care, instruction or expertise can eliminate. If such things occur you can be seriously injured or die, even when using safety equipment and other precautions. **RIDE AT YOUR OWN RISK AND USE COMMON SENSE.**

This manual contains many warnings and cautions concerning the consequences of failing to maintain, inspect or properly use your electric mini bike. Because any incident can result in serious injury or even death, we do not repeat the warning of possible serious injury or death each time such a possibility is mentioned.

## APPROPRIATE RIDER USE AND PARENTAL SUPERVISION

This manual contains important safety information. It is your responsibility to review this information and make sure that all riders understand all warnings, cautions, instructions and safety topics and assure that young riders can safely and responsibly use this product. EVOLT recommends that you periodically review and reinforce the information in this manual with younger riders, and that you inspect and maintain your child's product to insure their safety. The recommended rider age is only an estimate, and can be affected by the rider's size, weight or skills. Any rider unable to fit comfortably on the Mini Bikes should not attempt to ride it. **A parent's decision to allow his or her child to ride this product should be based on the child's maturity, skill and ability to follow rules.**

DO not exceed the maximum recommended rider weight.

**⚠WARNING:** Rider weight does not necessarily mean a person's size is appropriate to fit or maintain control of the vehicles.

Keep this product away from small children and remember that this product is intended for use only by persons who are completely comfortable and confident when operating the products.

Do not touch the brakes or electric motor on your electric mini bike when in use as they can become very hot.

Refer to the section on safety for additional warnings.

## ACCEPTABLE RIDING PRACTICES AND CONDITIONS

Always check and obey any local laws or regulations which may affect the locations where the vehicles may be used.

Ride defensively. Watch out for potential objects that could catch your wheel or force you to swerve suddenly or lose control. Be careful to avoid pedestrians, skaters, skateboards, scooters, bikes, children or animals who may enter your path, and respect the rights and property of others.

The Mini Bikes are meant for use only in controlled environments free of potential traffic hazards and not on public streets or sidewalks. Do not ride your electric mini bike in any areas where pedestrian or traffic is present.

Do not activate the speed control on the hand grip unless you are on the electric mini bike and in a safe, outdoor environment suitable for riding.

# Safety Warnings

These bikes were manufactured for performance and durability but are not impervious to damage. Jumping or other aggressive riding can over-stress and damage any product, including the electric motorbike, and the rider assumes all risks associated with high-stress activity.

Be careful and know your limitations. Risk of injury increases as the degree of riding difficulty increases. The rider assumes all risk associated with aggressive riding activities.

Maintain a hold on the handlebars at all times.

Never carry passengers or allow more than one person at a time to ride the electric mini bike.

Never use near steps or swimming pools. Keep your fingers and other body parts away from the drive chain, steering system, wheels and all other moving components.

Never use headphones or a cell phone when riding.

Never hitch a ride with another vehicle.

Do not ride the vehicles in wet or icy weather and never immerse the electric mini bike in water, as the electrical and drive components could be damaged by water or create other possibly unsafe conditions. These vehicles are intended for use on flat, level ground without loose debris such as rocks or gravel. Wet, slick, bumpy, uneven or rough surfaces may impair traction and contribute to possible accidents. Do not ride the electric mini bike in mud, ice, puddles or water. Avoid excessive speeds that can be associated with downhill rides. Never risk damaging surfaces such as carpet or flooring by use of an electric mini bike indoors. Do not ride at night or when visibility is limited.

## PROPER RIDING ATTIRE

Always wear proper protective equipment such as an approved safety helmet (with chin strap securely buckled). A helmet may be legally required by local law or regulation in your area. Elbow pads and knee pads, a long-sleeved shirt, long pants and gloves are recommended. Always wear athletic shoes (lace-up shoes with rubber soles), never ride barefooted or in sandals, and keep shoelaces tied and out of the way of the wheels, motor and drive system.

## USING THE CHARGER

The charger supplied with the electric mini bike should be regularly examined for damage to the cord, plug, enclosure and other parts, and in the event of such damage, the bike must not be charged until the charger has been repaired or replaced.

● Use only with the recommended charger. Do not use Lead-Acid charger with Li-ion battery and vice versa.

● Use the E-Volt charger

● Use caution when charging. The charger is not a toy and should be operated by an adult.

● Do not operate charger near flammable materials.

● Unplug charger and disconnect from bike when not in use.

● Chargers are not waterproof and should never be used in wet conditions. Serious injury or death could result.

**FAILURE TO USE COMMON SENSE AND HEED THE ABOVE WARNINGS INCREASES RISK OF SERIOUS INJURY. USE WITH APPROPRIATE CAUTION AND SERIOUS ATTENTION TO SAFE OPERATION.**

# Before You Begin

Remove contents from box. Remove the foam separators that protect the components from damage during shipping. Inspect the contents of the box for scratches in the paint, dents or kinked cables that may have occurred during shipping. Because these vehicles are 95 percent assembled and packed at the factory, there should not be any problems, even if the box has a few scars or dents.

## **MAKE SURE POWER SWITCH IS TURNED "OFF" BEFORE CONDUCTING ANY MAINTENANCE PROCEDURES.**

E-Volt recommends assembly and maintenance by an adult. Allow up to 30 minutes for assembly.

The Minibike allow up to 12 hours for initial charge (see page 8-9 for charging information).

During assembly, you can familiarize yourself with the vehicles components and design.

Enjoy the process and take your time to insure all components are safe and secure!

## **⚠ WARNING:**

**DO NOT USE NON- E-Volt PRODUCTS WITH YOUR E-Volt VEHICLES.**

These vehicles have been built to certain E-Volt design specifications. The original equipment supplied at the time of sale was selected based on its compatibility with the frame, fork and all other parts. Certain after market products may or may not be compatible and may void your warranty.

## **ADDITIONAL PARTS LOCATION**

Located within the center packing foam you will find the charger and tool kit. Within this package the handel bar clamps and hardware are also located. **DO NOT DISCARD.**

## **REQUIRED TOOLS**

10-12mm open wrench (Included)



14-17mm open wrench (Included)



# Assembly and Set-Up

## 1. Install front fork assembly

- 1> Mount the front fork assembly to the head pipe with M10×170 hexagon flange face bolt and M10 hexagon flange face locking nut;
- 2> Two M8×16 hexagon flange face bolts were used to assemble the upper coupling plate with the front fork assembly
- 3> Tighten the bolts using a 12-14mm and 14-17mm open wrench.

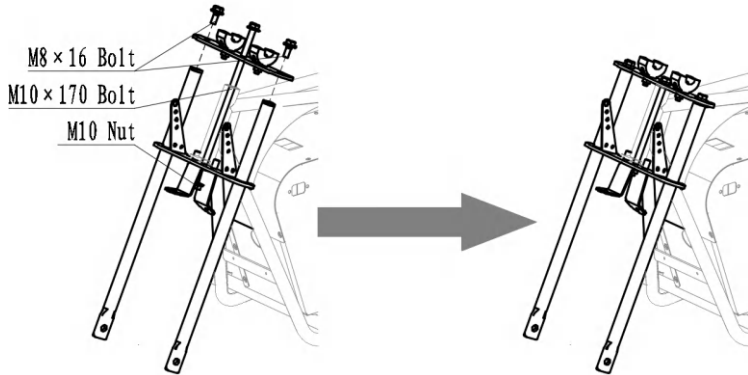

## 2. Install Front fender

- 1> Mount the Front fender to the front fork assembly with M6×16 hexagon flange face bolt and M6 hexagon flange face locking nut;
- 2> Tighten the bolts using a Phillips screwdriver and 8-10mm open wrench.

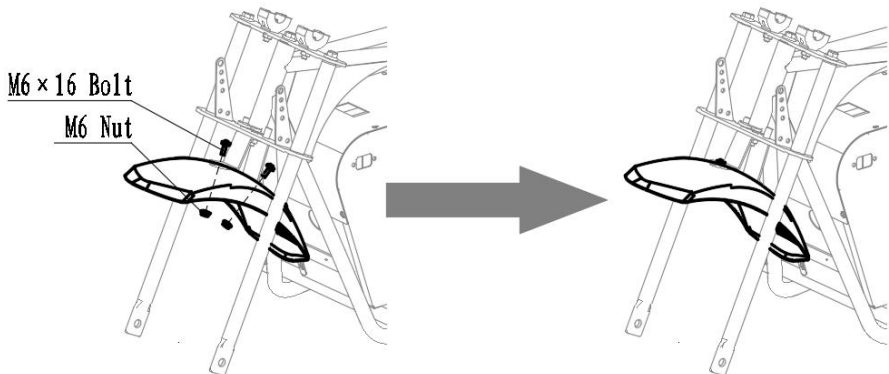

# Assembly and Set-Up

## 3. Install front wheel

1> M12 x 225 bolt (front axle) is successively passed through The left wheel axle hole on The front fork - 13 x 20 x 3.0 flat Washer → Front wheel → 13x20x3.0 flat washer → right front axle hole, and fastened with M12 hexagonal flange surface locking nut.

2> Tighten the bolts using a 12 - 14mm and 14-17mm open wrench.

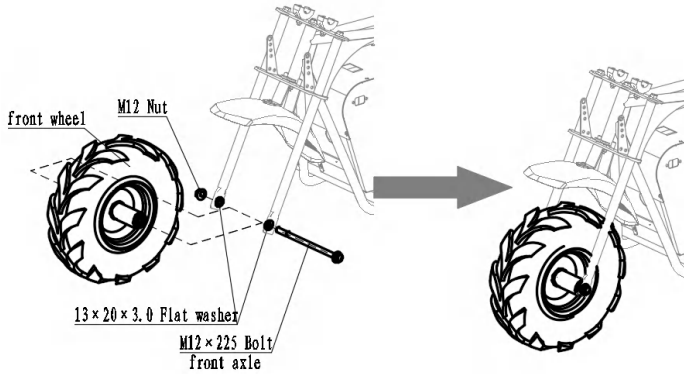

## 4. Install Head lamp

1> Mount the Head lamp to the front fork assembly with M8x16 hexagon flange face bolt.

2> Tighten the bolts using a 12 - 14mm open wrench.

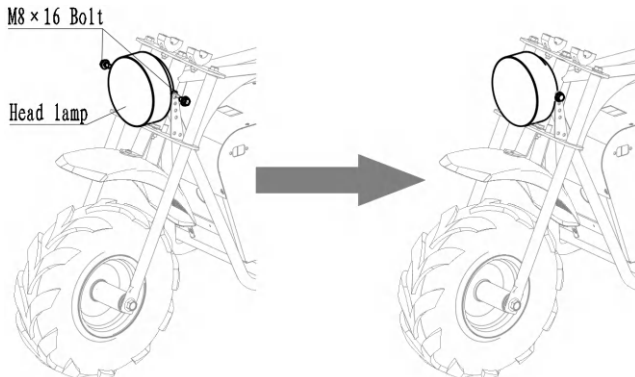

# Assembly and Set-Up

## 4. Install handlebar tube

- 1>Place the handlebars in the handlebar clamps. Make sure cables are not twisted or kinked.
- 2>Mount the handlebar tube to the front fork assembly with M8×25 hexagon flange face bolt;
- 3>Tighten the bolts using a 6mm Hex Key wrenches.

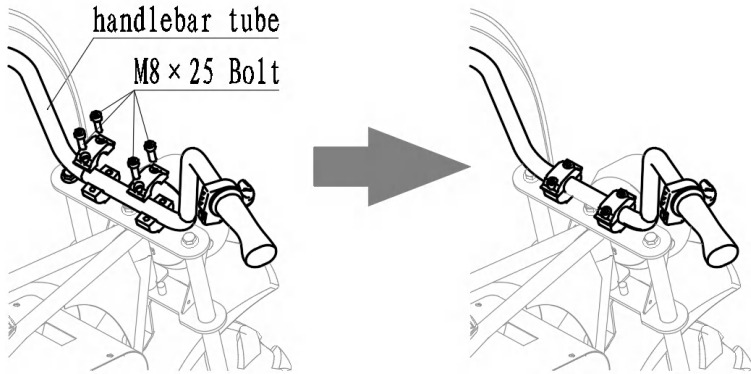

## 5. Adjust the governor and brake handle

Adjust the governor and brake handle to the proper position, Tighten the bolts using a 4mm and 5mm Hex Key wrenches.

Rotate the front fork from side to side making sure that the wires and cables are free. Squeeze the brake handle a couple times to loosen up the brake. Spin the rear wheel making sure it spins free, **Without brake drag**

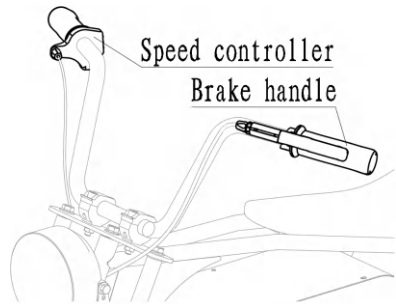

### **⚠WARNING:**

Failing to properly adjust and tighten the bolts that affix the handlebars can cause you to lose control and crash.

**Mini Bike had a key. The key "OFF" before conducting any maintenance procedures. Keyed on/off for parental safety.**



# Assembly and Set-Up

## Inflating the Tires

tires are fully inflated at the factory.

When the tire pressure is insufficient, using a 45 degree tire chuck, inflate both tires 10PSI. We strongly recommend 24 PSI for adults up to 160lb(71Kg) when using this product. Proper Tire pressure is VERY IMPORTANT. Do not squeeze the tire and assume it is correct. For the best performance and range this must be checked regularly—Low tire pressure reduces range and speed.

Please Note: There is a tire information label located on the left side of the rear fork with this information as well.



## Key Switch Operation

All E-Volt Series minibikes come with keyed switches so use can be restricted to owners and parental control is available. We send 2 keys with each unit and we highly recommend you save one of these keys in a safe place. The key requires only a single turn to turn the vehicle on.

### light switch

light switch is located on the handlebar left. Factory setting, running light will be on after opening the key

### Safety Speed Limiter Switch

H-M-L speed switch is located on the throttle control.

"L" is low-speed gear, and the maximum speed is 11mph.

"M" is Medium-speed gear, and the maximum speed is 16mph.

"H" is High-speed gear, at this time the maximum speed is 21mph.



# Before Riding

All EVOLT electric ride on bikes are set on low speed when they are shipped. You should change this setting only when you feel the rider can control the vehicle at higher speeds.

## The Lead-Acid Battery

Your new electric mini bike is partially charged from the factory. Charge before Riding

### Standard Lead-Acid

To achieve the best performance and life from your new battery, the first charge and full discharge cycles are important. **After the first charge**-Run the battery down (not dead) and then recharge completely. This will format the battery. To get the longest life out of your lead-acid batteries recharge them **Completely** after every ride, even very small rides. Leaving the battery pack in a partially discharged state may cause internal sulfation of the batteries which lowers the useful lifespan of the batter pack.

- Initial charge time up to 12 hours
- Recharge time: up to 8 hours, depending on level of depletion.
- Fully charge battery before storing.
- When the minibike is not in regular use, recharge the battery at least once a month until normal use is resumed.

### Standard Charger

Lead-Acid Battery

Green light means ready.

Red light means charging.

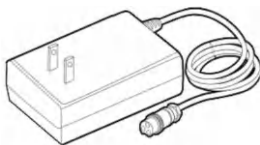

Note: Make sure power is turned OFF when unit is not in use. If the power switch is left on for an extended period, the battery may reach a stage at which it will no longer hold a charge.

### ⚠ WARNING:

To avoid a pinch or injury keep fingers away from moving sprockets and chain.

### ⚠ WARNING:

To prevent shock, please follow the instructions accordingly and do not skip or combine any steps.

### ⚠ WARNING:

Rechargeable batteries are only to be charged under adult supervision. Always disconnect your electric mini bike from the charger before cleaning with liquid.

Note: If your charger does not look like the one illustrated, your unit may have been supplied with an alternative charger. The specifications and charging procedure would not change. The charger has a small window with one LED to indicate the charge status. A green light indicates the charger is ready to be plugged into the bike and a red light indicates charging. After the unit is fully charged the indicator will return to a green light signifying the ready condition. Refer to the illustration on the charger unit for the actual "charging" and "charged" status indications for your model charger. Chargers have built-in overcharge protection to prevent battery from being overcharged. Charger will get warm during use. This is normal for some chargers and is no cause for concern. If your charger does not get warm during use, it does not mean that it is not working properly.

**Turn power switch "OFF" before charging and conducting any maintenance procedures.**

# Before Riding

## Charging the Battery

Runtime may vary depending on many factors such as riding conditions, rider weight, climate and/or proper maintenance, specifically tire pressure.

Lead-Acid Full recharge in 6 to 8 hours. Average battery life: 250 charge/discharge cycles. To get the longest life out of your batteries recharge them after every ride. Leaving your batteries in a partially discharged state can cause internal sulfation which lowers the performance and life of the battery pack. Do not charge in extreme temperature above 110°F or below 32°F. Charging in extreme temperatures above 110°F and below 32°F can cause damage to battery. Always store in cool dry area with no more than 50% charge.

1. Plug the charger into a wall outlet FIRST. If the lights on charger do not light up, check the power to the outlet. If necessary, try a different outlet.

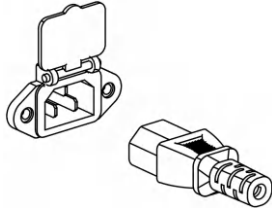

2. Make sure Mini bike power switch is OFF before charging. AFTER the green light comes on located on the charger you can plug the charger into the charger port to charge battery. Align plug and socket correctly! Plug should slip in socket without excessive force. The green light indicates on or fully charged. Red light indicates charging.

## ⚠️WARNING:

Failure to recharge the Lead-Acid battery at least once a month may result in a battery that will no longer hold a charge.

## ⚠️WARNING:

Lead acid and Li-ion battery chargers are not interchangeable. Make sure you are using the correct charger for the battery type you have. Serious damage could result.

Use only E-Volt recommended battery charger for the battery type used!

# Safety Reminders

## PRE-RIDE CHECKLIST

### Loose Parts

Check and secure all fasteners before every ride. Make sure handlebar clamp bolts are locked properly in place. There should not be any unusual rattles or sounds from loose parts or broken components. If you are not sure, ask an experienced mechanic to check.

### Brake

Check the brake for proper function. When you squeeze the lever, the brake should provide positive braking action. When you apply the brake with the speed control on, the brake cut-off switch will stop the motor. When the brake is not in use, the rear wheel should spin freely without drag.

### Frame, Fork and Handlebars

Check for cracks or broken connections. Although broken frames and chassis components are rare, it is possible for an aggressive rider to run into a curb or wall and wreck, bend or break a frame, fork or suspension components. Get in the habit of inspecting your regularly.

### Tire Inflation

Tires are **Not Fully** inflated when shipped. Using an air compressor equipped with a 45 degree end, inflate both tires to  $5 \pm 0.5$  PSI. Heavier riders use 5 PSI. This information is also located on the left side of the rear fork for easy access. Periodically inspect the tires for excess wear, and regularly check the tire pressure and re-inflate as necessary.

### Safety Gear

Always wear proper protective equipment such as an approved safety helmet, elbow pads and kneepads. Always wear athletic shoes (lace-up shoes with rubber soles), never ride barefooted or in sandals, and keep shoelaces tied and out of the way of the wheels, motor and drive system.

# Repair and Maintenance

**WARNING:** Turn keys “OFF” before conducting any maintenance procedures.

## Adjusting the Brakes

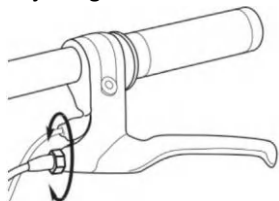

To adjust the tension, thread the brake lever adjuster in or out  $1/4$  to  $1/2$  turn until the desired brake adjustment is attained. Most adjustments are complete at this step. If brake still needs further adjustment, proceed to step 2

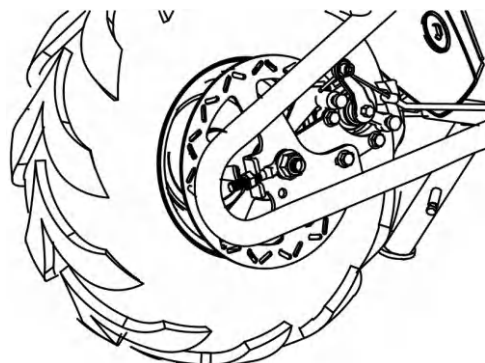

If the brake has too much slack, use a 10mm wrench to loosen the brake anchor cable for additional adjustment.

## Testing the Brakes

To use the brake, squeeze the lever to increase the pressure on the brake. The brake lever is fitted with a cable adjuster to compensate for cable stretch and/or to fine-tune the lever movement to brake engagement. If brake is not engaging properly, follow instructions for adjusting the brakes, make sure brakes is NOT adjusted to tight.

## **⚠WARNING:**

The brake can cause the electric motorbike to skid the tire throwing an unsuspecting rider. Practice in an open area free from obstacles until you are familiar with the brake function. Avoid skidding to a stop as this can cause you to lose control or damage the rear tire.

**Note: Brakes adjusted to tight and dragging will cause excessive wear and poor performance.**

# Repair and Maintenance

## Chain Adjustment, Rear Tire and Chain Replacement

Tools required: Screwdriver, 5mm hex key wrench, 10mm, 12mm, 14mm and 17mm wrench

1. Loosen screws and remove chain guard.

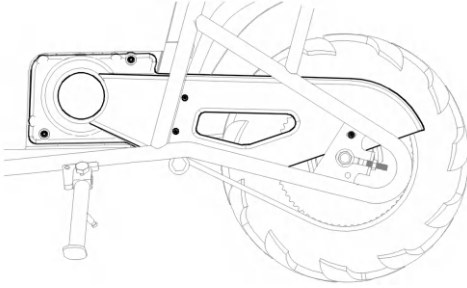

2. With a 5mm Hex Key wrench remove Brake Mounting Plate adjuster screw (A). Loosen the brake cable anchor bolt and remove cable (B) If replacing tire also remove 2 Brake caliper mounting bolts (C) and remove caliper.

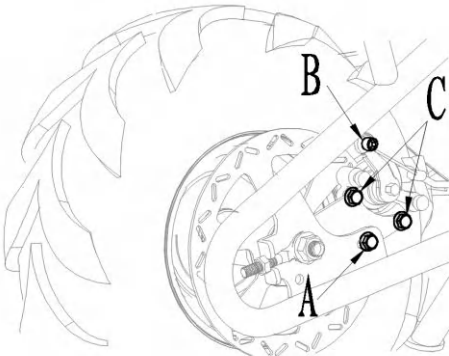

### **⚠ WARNING:**

Make sure power switch is in off position before performing any maintenance.

### **⚠ WARNING:**

To avoid a pinch or injury keep fingers away from moving sprockets and chain.

# Repair and Maintenance

## Chain Adjustment, Rear Tire and Chain Replacement

3. With 14mm and 17mm wrenches, loosen the axle. Remove the rear axle and remove the chain from the sprocket--pull the wheel out.

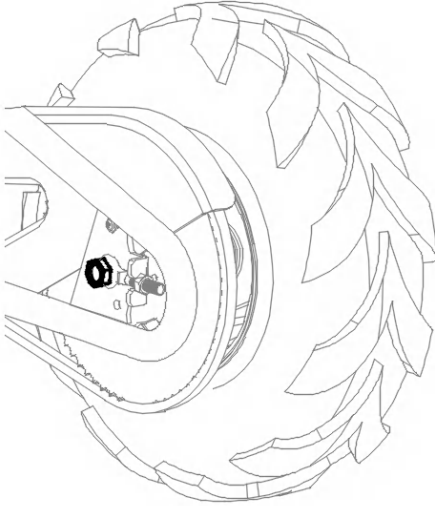

Replacing the chain requires removal of a Master Link. Removing outer retainer allows this link to be removed. Be careful not to damage clip. Note. Install clip as shown

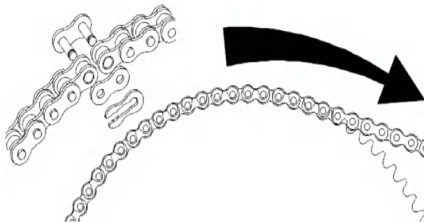

### **⚠ WARNING:**

Make sure power switch is in off position before performing any maintenance.

### **⚠ WARNING:**

To avoid a pinch or injury, keep fingers away from moving sprockets and chain

# Repair and Maintenance

Note the sequence of the hardware for assembly

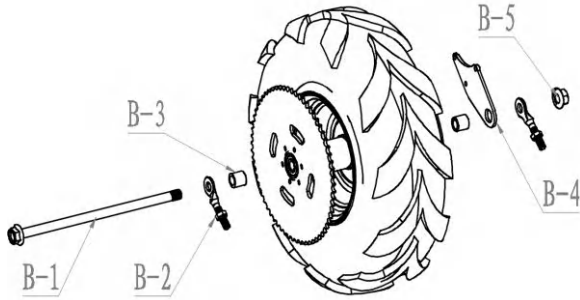

B-1 Rear Wheel Axle

B-2 Rear Axle Adjuster (2)

4. Install the new chain or wheel by slipping the chain around the axle. Slide the axle with hardware into the slots on the frame. Maneuver the chain onto the sprocket on the rear wheel and motor.

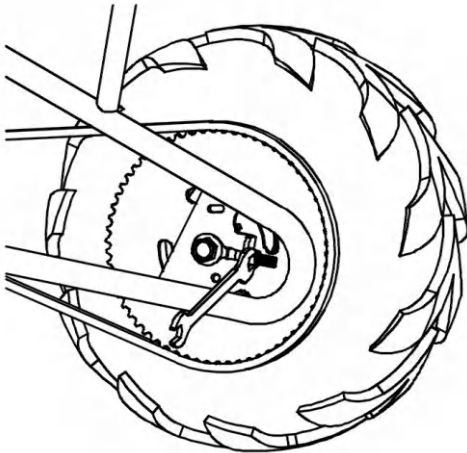

5. Tighten chain adjusters using 12mm wrench evenly to remove some slack from the chain as required.

B-3 Spacer (2)

B-4 Mounting Plate-Brake Caliper

B-5 Hexagon flange face lock nut

**⚠WARNING:**

Make sure power switch is in OFF position before performing any maintenance.

**⚠WARNING:**

To avoid a pinch or injury, keep fingers away from moving sprockets and chain.



# Repair and Maintenance

6. Adjust chain tension to have approx. 1/2" of free play. Free play is not forced! The chain should move this amount with very little force. Using 14mm and 17mm wrenches tighten axle securely. Chain tension must be correct with axle tightened securely (fig A). Snug chain adjuster bolts after axle is tight.

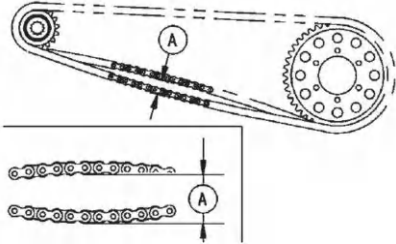

7. Thread the cable wire into the cable anchor. Install the cable to its original position and tighten securely

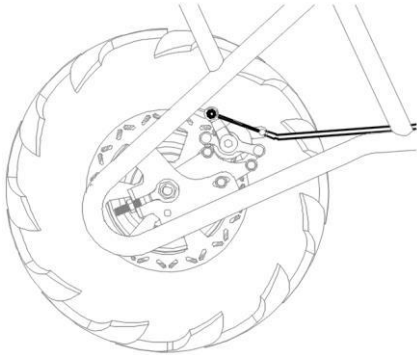

8. Tighten the brake mount plate bolts (A) and (C) securely. Re-attach the chain guard. Test ride. Readjust as needed.



**Chain and Sprocket Notes:** The chain will typically have a "loose spot" and "tight spot" corresponding with a sprocket rotational position. This is normal and common to all chain-driven products due to run-out tolerances

of the sprockets. The chain should be adjusted to the ideal tension with chain in the tightest spot.

Proper chain alignment must be maintained. The wheel must not be skewed.

If the chain is noisy or rough running, check the lubrication, tension and alignment of the sprockets, in that order.

## **⚠WARNING:**

To avoid a pinch or injury keep fingers away from moving sprockets and chain.

## **⚠WARNING:**

Make sure power switch is in OFF position before performing any maintenance.

# Repair and Maintenance

## Replacing the Fuse Lead-Acid Battery (ONLY)

Remove the rubber cover from the top of the battery case.

Locate the fuse box attached to the batteries. Open the fuse cover to expose the fuse.

Remove the fuse and replace with a new one of equal amperage. A small spark may occur when install the new fuse. Requires 50-amp fuse. Close the fuse cover and reattach the battery cover.

Battery Replacement.

**Lead-Acid** batteries (4-12v 12ah) should be replaced in sets only and with original EVOLT Batteries!

Retailers do not have the same quality as our OEM batteries. Performance may be seriously affected

Disconnect battery connection.

Re-install new battery set and reconnect.

When reconnecting new battery set you may get a small spark.

Tuck in wires and reassemble.

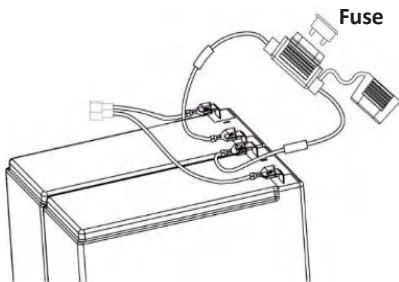

## **⚠WARNING:**

To avoid a pinch or injury keep fingers away from moving sprockets and chain.

## **⚠WARNING:**

To prevent shock, please follow the instructions accordingly and do not skip or combine any steps.

# Repair and Maintenance

## Battery Care and Disposal (Lead-Acid)

Do not store the battery in temperatures above 110 °F or below 32° F.



Contains sealed non-spillable lead-acid batteries. Batteries must be recycled.

**Disposal:** E-Volt product uses sealed lead-acid batteries which must be recycled or disposed of in an environmentally sound manner. Do not dispose of a lead-acid battery in a fire. The battery may explode or leak. Do not dispose of a lead-acid battery in your regular household trash. The incineration, land filling or mixing of sealed lead-acid batteries with household trash is prohibited by law in most areas. Return exhausted batteries to a federal or state approved lead-acid battery recycler or a local seller of automotive batteries.

## Charger Care and Disposal

The charger supplied with the bike should be regularly examined for damage to the cord, plug, enclosure and other parts, and, in the event of such damage, the mini bike must not be charged until it has been repaired or replaced.

Charger should be recycled or disposed of in an environmentally sound way.

For Lead-Acid Battery Use E-Volt Charger

### Use only E-Volt Chargers

Electric Mini Bike must be recycled or disposed of in an environmentally sound manner.

## **⚠WARNING:**

If **Lead-Acid** battery leak develops, avoid contact with the leaking acid and place the damaged battery in a plastic bag. Refer to the disposal instructions at left. If acid comes into contact with skin or eyes, flush with cool water for at least 15 minutes and contact a physician.

## **⚠WARNING:**

Do not charge or discharge the battery in extreme temperatures.

Do not short-circuit the positive (+) and negative (-) terminals of the battery.

Do not immerse the battery into liquids or allow it to get wet.

The battery should be stored in a clean, dry area. Discharging and recharging the battery every 6 months is recommended.

Keep away from fire.

**Do not disassemble the battery**

# Troubleshooting Guide

Problem	Possible Cause	Solution
Short run time (less than 15 minutes per charge)	Battery is old and will not accept full charge	Even with proper care, a rechargeable battery does not last forever. Average SLA battery life, 1 to 2 years-300 cycles Li-ion battery life, 3 to 4 years-500 cycle Replace only with E-Volt battery.
	Tires are not properly inflated	The tires are inflated when shipped but they invariably will lose some pressure between the point of manufacturing and your purchase. Refer to instructions on <b>page 7</b> of this manual to properly inflate tires.
	Brakes are not adjusted properly	Refer to brake adjustment instructions on <b>page 11</b> of this manual.
Mini bike runs sluggishly	Riding conditions are too stressful	Use only on solid, flat, clean and dry surfaces such as pavement or level ground.
	Mini bike is overloaded	Make sure you do not overload the mini bike by allowing more than one rider at one time, exceeding the maximum weight limit, going up too steep a hill or towing objects behind the vehicle.
	3 speed switch in the low position	Refer to <b>page 7</b> for switching instructions.
	Brake adjusted to tight and Dragging	Refer to <b>page 11</b> for brake adjustment
Sometimes the Mini bike doesn't run, but other times it does	Loose wires or connectors	Check all wires around the motors and all connectors to make sure they are tight.
	Motor or electrical switch damage	Contact your local authorized E-Volt dealer for diagnosis and repair.
Charger gets warm during use	Normal response to charger use	No action required. This is normal and is no cause for concern. If your charger does not get warm during use, it does not mean that it is not working properly.

# Troubleshooting Guide

Problem	Possible Cause	Solution
Mini bike does not stop when applying the brake	Brakes are not adjusted properly	Refer to instructions on <b>page 11</b> of this manual to properly adjust brakes.
Mini bike makes loud noises or grinding sounds	Chain is too dry and or not adjusted properly	Apply a lubricant such as 3 in 1TM or Tri-Flow TM or motorcycle chain lube the chain. Refer to <b>page 14</b> for adjustment and alignment instruction

**NOTICE:**The battery charger is not waterproof. Moisture and water will damage the working of your charger. Always use in a cool, dry and clean environment.

# Side View

Note: The MiniBike has a 50 amp fuse that sits on top of the battery compartment-Do not over load!! We recommend max of 1.4 Amps per plug. This is not a fused circuit and overloading or shorting this circuit will cause Controller Failure! See page 18 for more information.  
**Never attempt to work on this circuit with the Key on!**

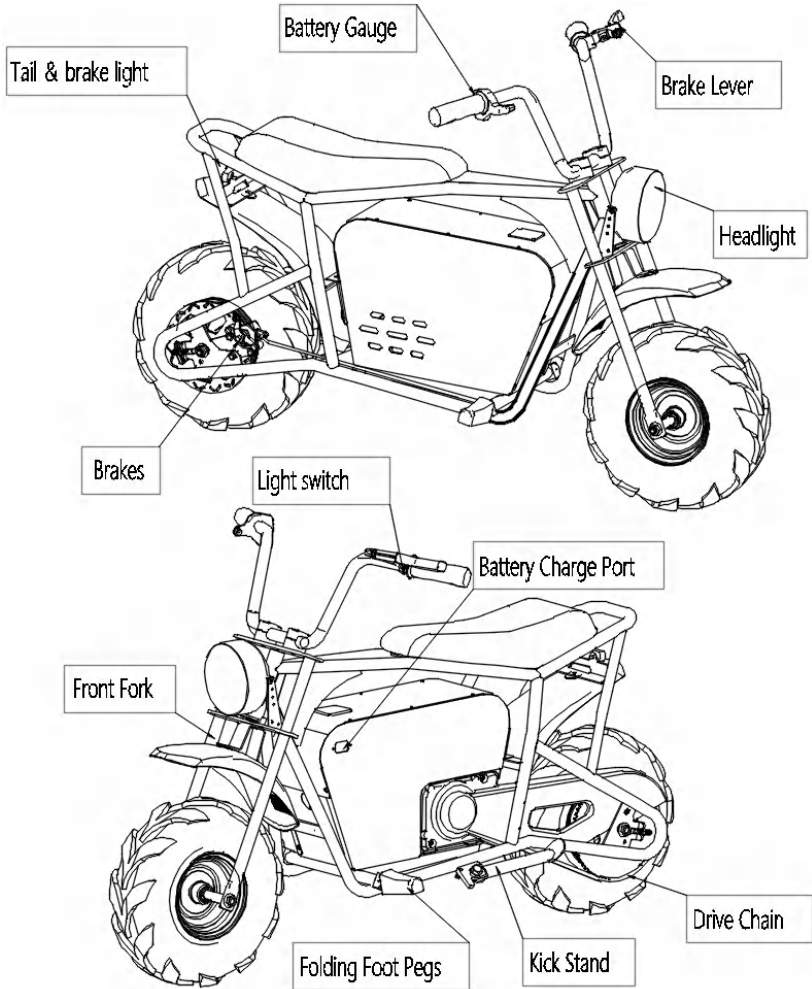

# Electrical Diagram

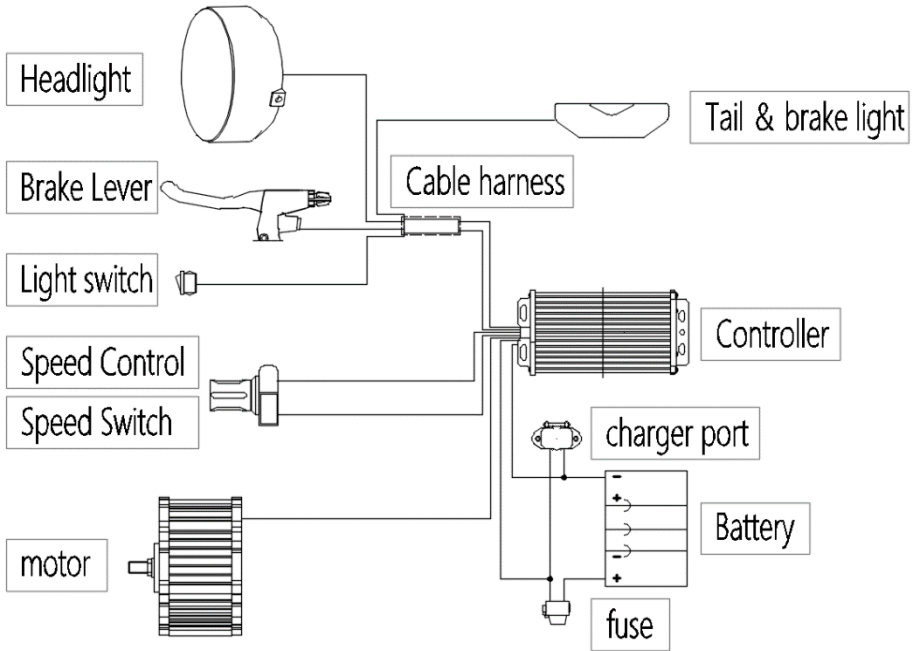

## WARNING

**THIS IS SPORTING EQUIPMENT AND NOT A TOY FOR YOUNGER CHILDREN USING THIS PRODUCT MAY BE A DANGEROUS ACTIVITY AND MAY RESULT IN INJURY OR DEATH EVEN WHEN USED WITH PROPER SAFETY PRECAUTIONS. USE AT YOUR OWN RISK.**

[www.evoltadventure.com](http://www.evoltadventure.com)

# EVOLT



COPYRIGHT © E-VOLT. ALL INFORMATION CONTAINED WITHIN THIS PUBLICATION IS BASED UPON THE LATEST PRODUCT SPECIFICATIONS AND INFORMATION AT THE TIME OF PUBLICATION. BECAUSE OF THE CONSTANT ENHANCEMENT IN THE QUALITY AND DESIGN OF PRODUCTION COMPONENTS, DISCREPANCIES MAY VARY BETWEEN THE ACTUAL VEHICLE AND THE INFORMATION PRESENTED IN THIS PUBLICATION. NO LIABILITY CAN BE ACCEPTED FOR OMISSIONS OR INACCURACIES. ANY REPRINTING OR REPRODUCTION, WHETHER WHOLE OR IN PART OF THIS PUBLICATION IS STRICTLY PROHIBITED.

**Version: 10012201**